



# SGM708

## Low-Cost, Microprocessor Supervisory Circuit

---

### GENERAL DESCRIPTION

The SGM708 microprocessor supervisory circuit reduces the complexity and number of components required to monitor power supply and monitor microprocessor activity. It significantly improves system reliability and accuracy compared to separate ICs or discrete components.

The SGM708 provides power supply monitoring circuitry that generates a reset output during power-up, power-down and brownout conditions. The reset output remains operational with  $V_{CC}$  as low as 1V.

In addition, there is a 1.25V threshold detector for power-fail warning, low-battery detection, or monitoring an additional power supply. An active-low manual-reset input ( $\overline{MR}$ ) is also included.

The SGM708 is available in Green SOIC-8 package. It operates over an ambient temperature range of  $-40^{\circ}\text{C}$  to  $+85^{\circ}\text{C}$ .

### FEATURES

- **Precision Supply-Voltage Monitor**
  - 4.65V for SGM708-L
  - 4.40V for SGM708-M
  - 4.0V for SGM708-J
  - 3.08V for SGM708-T
  - 2.93V for SGM708-S
  - 2.63V for SGM708-R
- **Guaranteed  $\overline{\text{RESET}}$  Valid at  $V_{CC} = 1\text{V}$**
- **200ms Reset Pulse Width**
- **Debounced TTL/CMOS-Compatible Manual-Reset Input**
- **Voltage Monitor for Power-Fail or Low-Battery Warning**
- **Dual Reset Outputs:**
  - (Active-Low and Active-High)
- **$-40^{\circ}\text{C}$  to  $+85^{\circ}\text{C}$  Operating Temperature Range**
- **Available in Green SOIC-8 Package**

### APPLICATIONS

Computers  
Controllers  
Intelligent Instruments  
Automotive Systems  
Critical  $\mu\text{P}$  Power Monitoring

## SGM708

### PACKAGE/ORDERING INFORMATION

MODEL	RESET THRESHOLD (V)	PACKAGE DESCRIPTION	ORDERING NUMBER	PACKAGE MARKING	PACKING OPTION
SGM708	4.65	SOIC-8	SGM708-LYS8G/TR	SGM708-LYS8	Tape and Reel, 2500
	4.40	SOIC-8	SGM708-MYS8G/TR	SGM708-MYS8	Tape and Reel, 2500
	4.0	SOIC-8	SGM708-JYS8G/TR	SGM708-JYS8	Tape and Reel, 2500
	3.08	SOIC-8	SGM708-TYS8G/TR	SGM708-TYS8	Tape and Reel, 2500
	2.93	SOIC-8	SGM708-SYS8G/TR	SGM708-SYS8	Tape and Reel, 2500
	2.63	SOIC-8	SGM708-RYS8G/TR	SGM708-RYS8	Tape and Reel, 2500

Green (RoHS & HSF): SG Micro Corp defines "Green" to mean Pb-Free (RoHS compatible) and free of halogen substances. If you have additional comments or questions, please contact your SGMICRO representative directly.

NOTE: Order number is defined as the follow:

#### ORDER NUMBER

**SGM 708- X Y X G / TR**

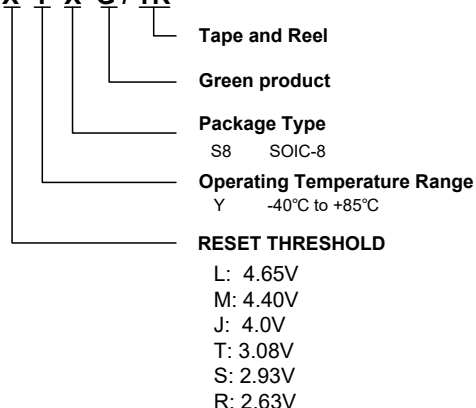

### ABSOLUTE MAXIMUM RATINGS

(Typical values are at  $T_A = +25^\circ\text{C}$ , unless otherwise noted.)

Terminal Voltage (with respect to GND)

$V_{CC}$ .....	-0.3V to 6.0V
All Other Inputs .....	-0.3V to ( $V_{CC} + 0.3V$ )
Input Current, $V_{CC}$ .....	20mA
GND .....	20mA
Output Current, (all outputs) .....	20mA
Operating Temperature Range .....	-40°C to +85°C
Junction Temperature .....	+150°C
Storage Temperature Range .....	-65°C to +150°C
Lead Temperature (Soldering, 10s) .....	+260°C
<b>ESD Susceptibility</b>	
HBM .....	4000V
MM .....	300V

### OVERSTRESS CAUTION

Stresses beyond those listed in Absolute Maximum Ratings may cause permanent damage to the device. Exposure to absolute maximum rating conditions for extended periods may affect reliability. Functional operation of the device at any conditions beyond those indicated in the Recommended Operating Conditions section is not implied.

### ESD SENSITIVITY CAUTION

This integrated circuit can be damaged by ESD if you don't pay attention to ESD protection. SGMICRO recommends that all integrated circuits be handled with appropriate precautions. Failure to observe proper handling and installation procedures can cause damage. ESD damage can range from subtle performance degradation to complete device failure. Precision integrated circuits may be more susceptible to damage because very small parametric changes could cause the device not to meet its published specifications.

### DISCLAIMER

SG Micro Corp reserves the right to make any change in circuit design, or specifications without prior notice.

TYPICAL APPLICATION CIRCUIT

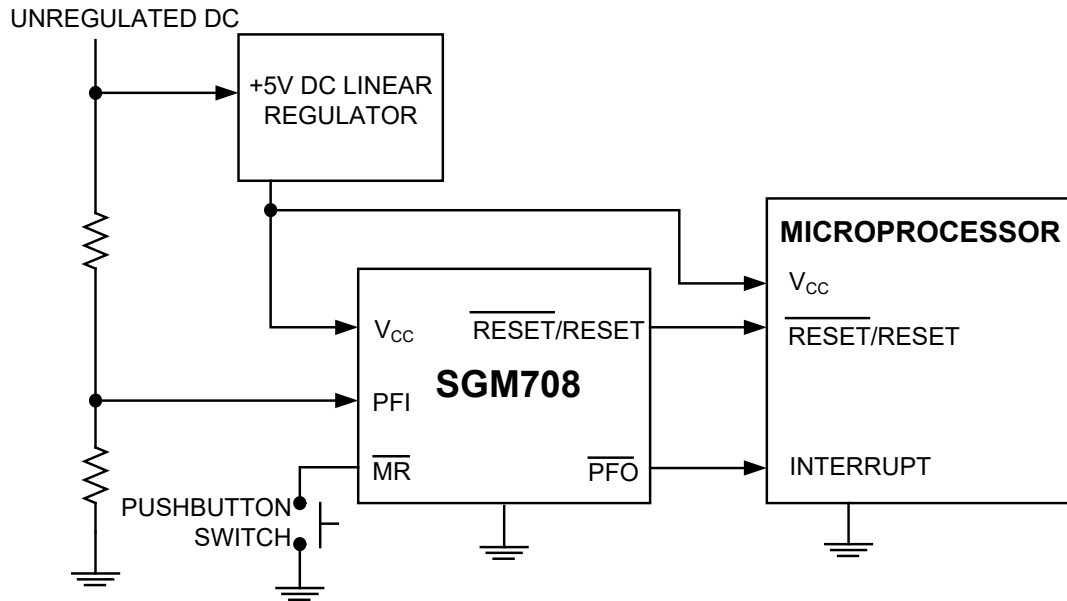

SGM708

PIN CONFIGURATION

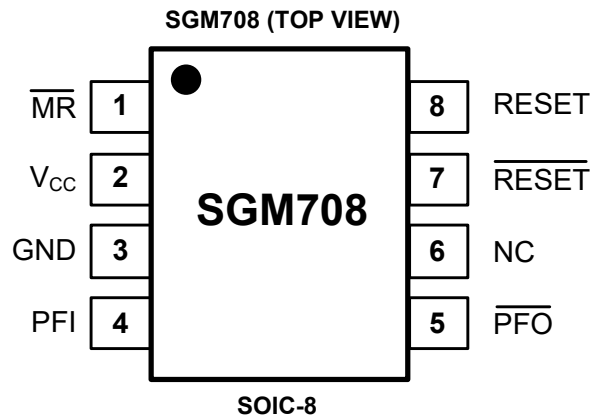

PIN DESCRIPTION

PIN	NAME	FUNCTION
1	$\overline{\text{MR}}$	Manual-Reset Input triggers a reset pulse when pulled below 0.8V. This active-low input has an internal 250 $\mu$ A ( $V_{\text{CC}} = +5\text{V}$ ) pull-up current. It can be driven from a TTL or CMOS logic line as well as shorted to ground with a switch.
2	$V_{\text{CC}}$	Power Supply Voltage that is monitored.
3	GND	0V Ground Reference for all signals.
4	PFI	Power-Fail Voltage Monitor Input. When PFI is less than 1.25V, $\overline{\text{PFO}}$ goes low. Connect PFI to GND or $V_{\text{CC}}$ when not used.
5	$\overline{\text{PFO}}$	Power-Fail Output goes low and sinks current when PFI is less than 1.25V; otherwise $\overline{\text{PFO}}$ stays high.
6	NC	No Connect.
7	$\overline{\text{RESET}}$	Active-Low Reset Output pulses low for 200ms when triggered, and stays low whenever $V_{\text{CC}}$ is below the reset threshold (4.65V for SGM708-L, 4.40V for SGM708-M, 4.0V for SGM708-J, 3.08V for SGM708-T, 2.93V for SGM708-S and 2.63V for SGM708-R). It remains low for 200ms after $V_{\text{CC}}$ rises above the reset threshold or $\overline{\text{MR}}$ goes from low to high.
8	RESET	Active-High Reset Output is the inverse of $\overline{\text{RESET}}$ . Whenever $\overline{\text{RESET}}$ is high, RESET is low, and vice versa.

## SGM708

### ELECTRICAL CHARACTERISTICS

( $V_{CC} = 4.75V$  to  $5.5V$  for SGM708-L;  $V_{CC} = 4.5V$  to  $5.5V$  for SGM708-M;  $V_{CC} = 4.07V$  to  $5.5V$  for SGM708-J;  $V_{CC} = 3.14V$  to  $5.5V$  for SGM708-T;  $V_{CC} = 2.95V$  to  $5.5V$  for SGM708-S;  $V_{CC} = 2.68V$  to  $5.5V$  for SGM708-R;  $T_A = -40^{\circ}C$  to  $+85^{\circ}C$ , unless otherwise noted.)

PARAMETER		CONDITIONS	MIN	TYP	MAX	UNITS
Operating Voltage Range ( $V_{CC}$ )			1.0		5.5	V
Supply Current ( $I_{SUPPLY}$ )				20	60	$\mu A$
Reset Threshold ( $V_{RT}$ )	SGM708-L		4.5	4.65	4.75	V
	SGM708-M		4.25	4.4	4.5	
	SGM708-J		3.91	4.0	4.07	
	SGM708-T		3.02	3.08	3.14	
	SGM708-S		2.85	2.93	2.95	
	SGM708-R		2.56	2.63	2.68	
Reset Threshold Hysteresis		SGM708-T, SGM708-S, SGM708-R		25		mV
		SGM708-J		35		
		SGM708-L, SGM708-M		40		
Reset Pulse Width ( $t_{RS}$ )			120	200	290	ms
$\overline{RESET}$ Output Voltage		$I_{SOURCE} = 800\mu A$	$0.7 \times V_{CC}$			V
		$I_{SINK} = 3.2mA$			0.4	
		$V_{CC} = 1V, I_{SINK} = 50\mu A$			0.3	
RESET Output Voltage		$I_{SOURCE} = 800\mu A$	$0.7 \times V_{CC}$			V
		$I_{SINK} = 1.2mA$			0.4	V
$\overline{MR}$ Pull-Up Current		$\overline{MR} = 0V$	100	250	600	$\mu A$
$\overline{MR}$ Pulse Width ( $t_{MR}$ )			250			ns
$\overline{MR}$ Input Threshold	Low	$T_A = +25^{\circ}C$			0.8	V
	High		2			
$\overline{MR}$ to Reset Out Delay ( $t_{MD}$ )				100	350	ns
PFI Input Threshold		$V_{CC} = 5V$	1.17	1.25	1.3	V
PFI Input Current				0.2		nA
$\overline{PFO}$ Output Voltage		$I_{SOURCE} = 800\mu A$	$0.7 \times V_{CC}$			V
		$I_{SINK} = 3.2mA$			0.4	

SGM708

FUNCTIONAL BLOCK DIAGRAM

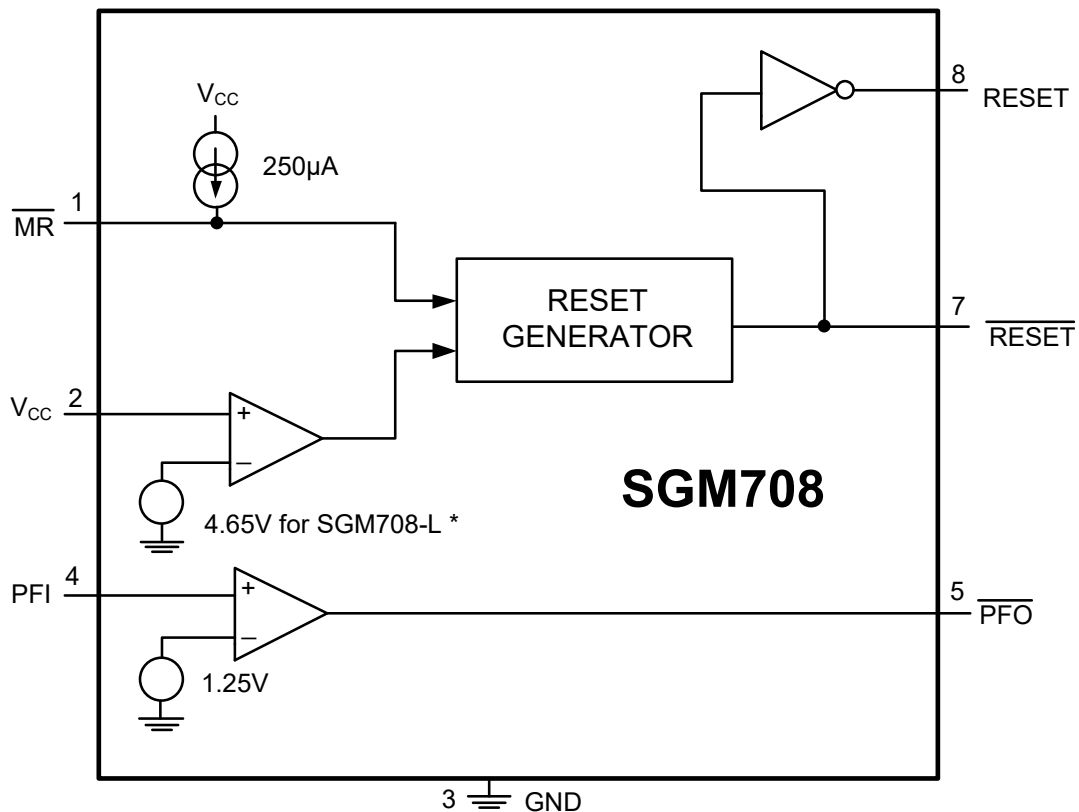

- \* 4.65V for SGM708-L
- 4.40V for SGM708-M
- 4.0V for SGM708-J
- 3.08V for SGM708-T
- 2.93V for SGM708-S
- 2.63V for SGM708-R

### TYPICAL PERFORMANCE CHARACTERISTICS

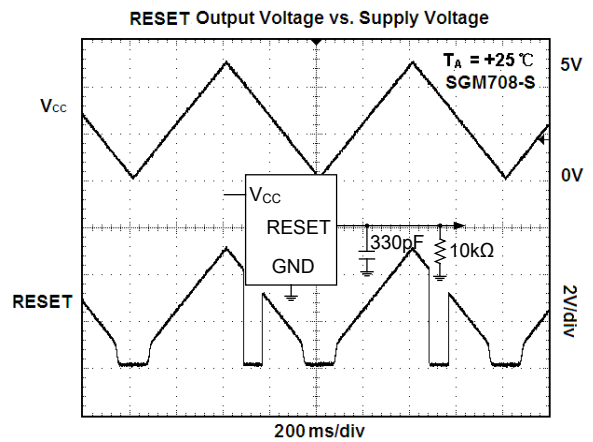
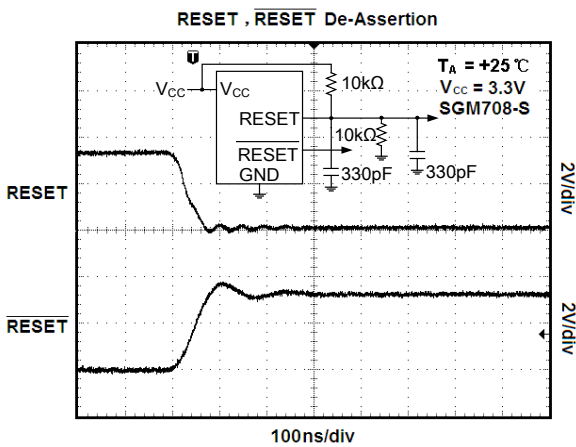
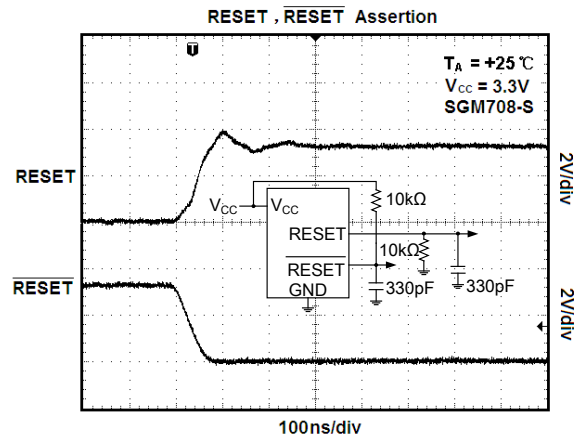
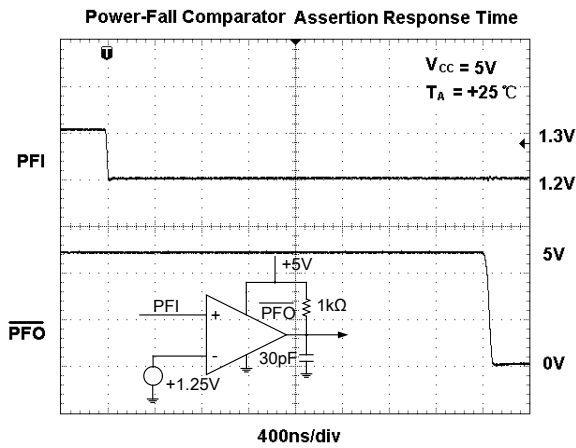
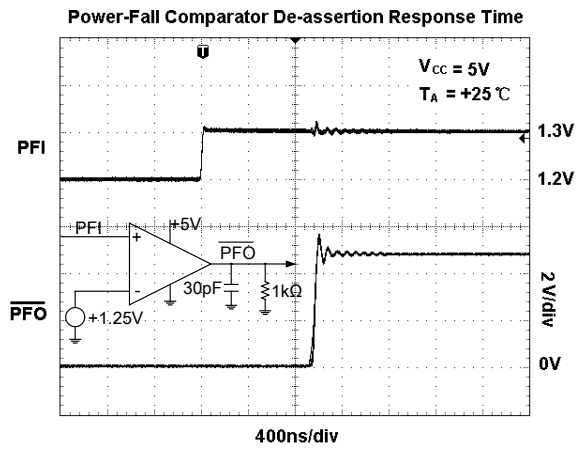
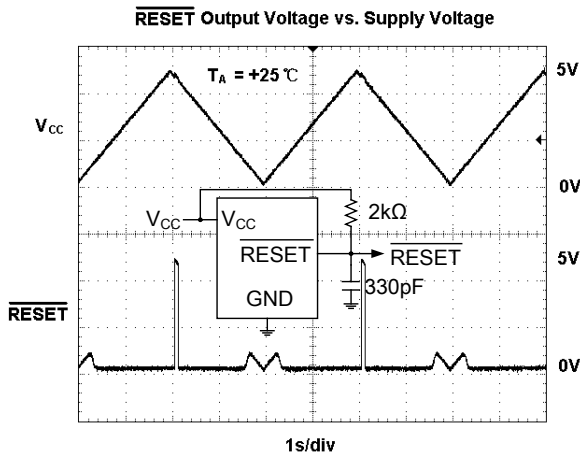

TYPICAL PERFORMANCE CHARACTERISTICS (continued)

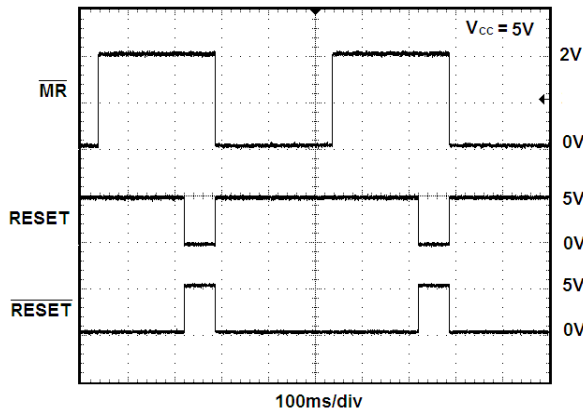
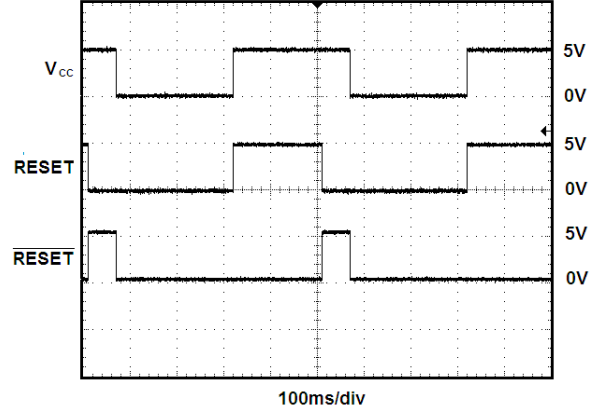
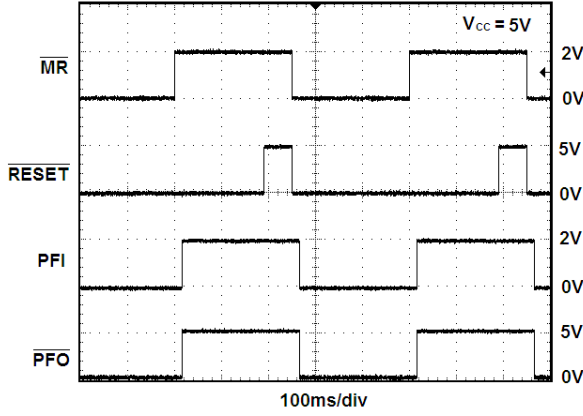

## SGM708

### APPLICATION INFORMATION

#### Ensuring a Valid $\overline{\text{RESET}}$ Output Down to $V_{CC} = 0V$

When  $V_{CC}$  falls below 1V, the SGM708  $\overline{\text{RESET}}$  output no longer sinks current—it becomes an open circuit. High-impedance CMOS logic inputs can drift to undetermined voltages if left undriven. If a pull-down resistor is added to the  $\overline{\text{RESET}}$  pin as shown in Figure 1, any stray charge or leakage currents will be drained to ground, holding  $\overline{\text{RESET}}$  low. Resistor value (R1) is not critical. It should be about 100k $\Omega$ , large enough not to load  $\overline{\text{RESET}}$  and small enough to pull  $\overline{\text{RESET}}$  to ground.

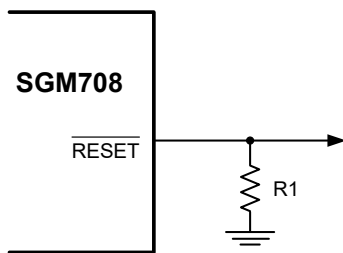

Figure 1.  $\overline{\text{RESET}}$  Valid to Ground Circuit

#### Monitoring Voltages Other Than the Unregulated DC Input

Monitor voltages other than the unregulated DC by connecting a voltage divider to PFI and adjusting the ratio appropriately. If required, add hysteresis by connecting a resistor (with a value approximately 10 times the sum of the two resistors in the potential divider network) between PFI and  $\overline{\text{PFO}}$ . A capacitor between PFI and GND will reduce the power-fail circuit's sensitivity to high-frequency noise on the line being monitored.  $\overline{\text{RESET}}$  can be asserted on other voltages in addition to the +5V  $V_{CC}$  line. Connect  $\overline{\text{PFO}}$  to  $\overline{\text{MR}}$  to initiate a  $\overline{\text{RESET}}$  pulse when PFI drops below 1.25V. Figure 2 shows the SGM708 configured to assert  $\overline{\text{RESET}}$  when the +5V supply falls below the reset threshold, or when the +12V supply falls below approximately 11V.

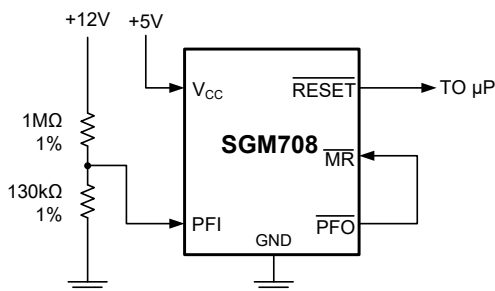

Figure 2. Monitoring Both +5V and +12V

#### Monitoring a Negative Voltage

The power-fail comparator can also monitor a negative supply rail (Figure 3). When the negative rail is good (a negative voltage of large magnitude),  $\overline{\text{PFO}}$  is low, and when the negative rail is degraded (a negative voltage of lesser magnitude),  $\overline{\text{PFO}}$  is high. By adding the resistors and transistor as shown, a high  $\overline{\text{PFO}}$  triggers reset. As long as  $\overline{\text{PFO}}$  remains high, the SGM708 will keep reset asserted ( $\overline{\text{RESET}}$  = low, RESET = high). Note that this circuit's accuracy depends on the PFI threshold tolerance, the  $V_{CC}$  line, and the resistors.

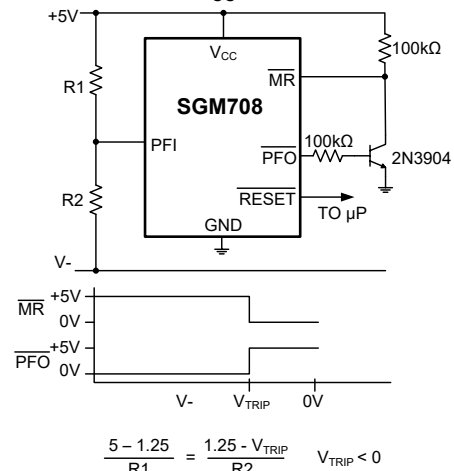

Figure 3. Monitoring a Negative Voltage

#### Interfacing to $\mu P$ s with Bidirectional Reset Pins

$\mu P$ s with bidirectional reset pins, such as the Motorola 68HC11 series, can contend with the SGM708  $\overline{\text{RESET}}$  output. If, for example, the  $\overline{\text{RESET}}$  output is driven high and the Microprocessor wants to pull it low, indeterminate logic levels may result. To correct this, connect a 4.7k $\Omega$  resistor between the  $\overline{\text{RESET}}$  output and the  $\mu P$  reset I/O, as in Figure 4. Buffer the  $\overline{\text{RESET}}$  output to other system components.

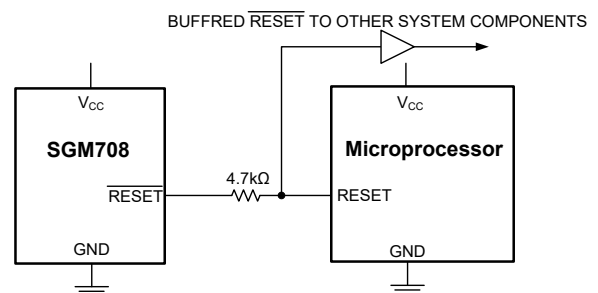

Figure 4. Interfacing to Microprocessors with Bidirectional Reset I/O

---

**REVISION HISTORY**

NOTE: Page numbers for previous revisions may differ from page numbers in the current version.

**DECEMBER 2017 – REV.A.3 to REV.A.4**

---

Changed Electrical Characteristics section ..... 5

---

**JANUARY 2013 – REV.A.2 to REV.A.3**

---

Added Recommended Land Pattern Information ..... 10  
Added Tape and Reel Information ..... 11, 12

---

**MARCH 2011 – REV.A.1 to REV.A.2**

---

Updated Package Description ..... All

---

**MAY 2010 – REV.A to REV.A.1**

---

Added Reset Threshold ..... All

---

**Changes from Original (APRIL 2010) to REV.A**

---

Changed from product preview to production data ..... All

---

PACKAGE OUTLINE DIMENSIONS

SOIC-8

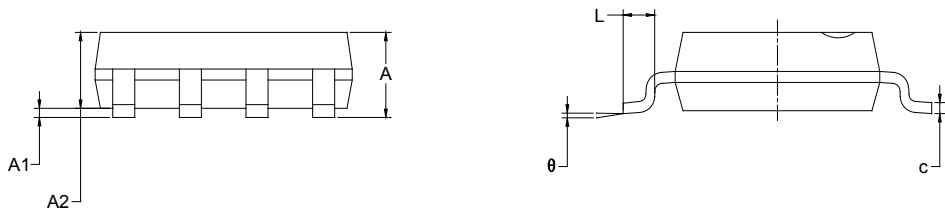
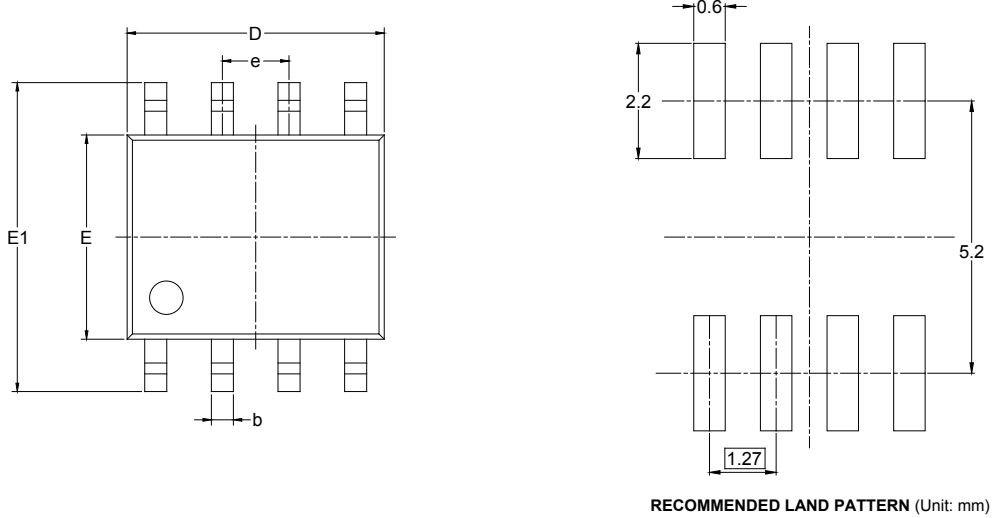

Symbol	Dimensions In Millimeters		Dimensions In Inches	
	MIN	MAX	MIN	MAX
A	1.350	1.750	0.053	0.069
A1	0.100	0.250	0.004	0.010
A2	1.350	1.550	0.053	0.061
b	0.330	0.510	0.013	0.020
c	0.170	0.250	0.006	0.010
D	4.700	5.100	0.185	0.200
E	3.800	4.000	0.150	0.157
E1	5.800	6.200	0.228	0.244
e	1.27 BSC		0.050 BSC	
L	0.400	1.270	0.016	0.050
θ	0°	8°	0°	8°

## TAPE AND REEL INFORMATION

### REEL DIMENSIONS

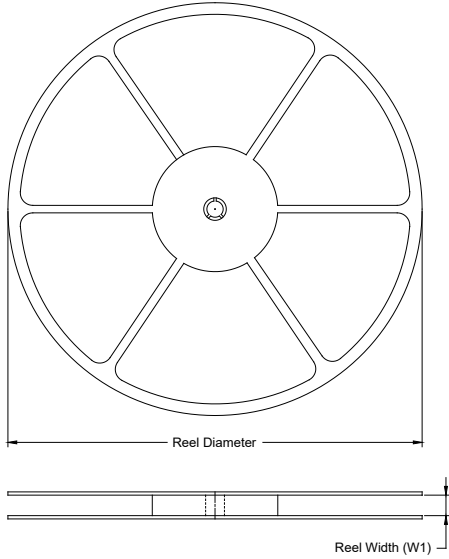

### TAPE DIMENSIONS

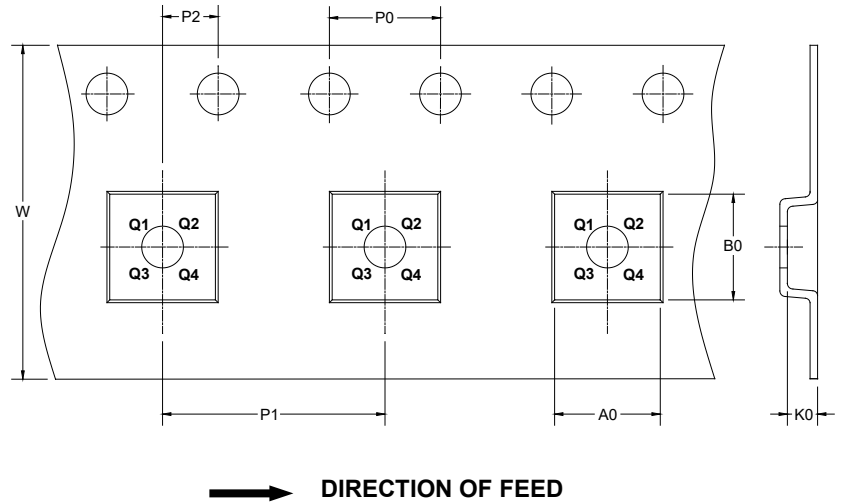

NOTE: The picture is only for reference. Please make the object as the standard.

### KEY PARAMETER LIST OF TAPE AND REEL

Package Type	Reel Diameter	Reel Width W1 (mm)	A0 (mm)	B0 (mm)	K0 (mm)	P0 (mm)	P1 (mm)	P2 (mm)	W (mm)	Pin1 Quadrant
SOIC-8	13"	12.4	6.40	5.40	2.10	4.0	8.0	2.0	12.0	Q1

000001

# PACKAGE INFORMATION

## CARTON BOX DIMENSIONS

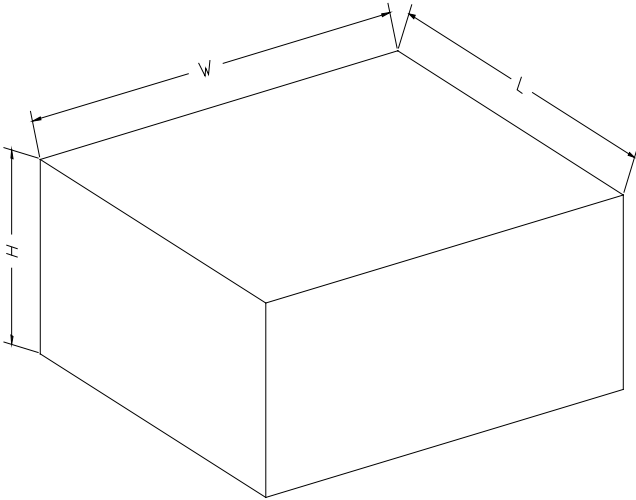

NOTE: The picture is only for reference. Please make the object as the standard.

## KEY PARAMETER LIST OF CARTON BOX

Reel Type	Length (mm)	Width (mm)	Height (mm)	Pizza/Carton
13"	386	280	370	5

DD0002