



## UC3842A/3843A

## LINEAR INTEGRATED CIRCUIT

### CURRENT MODE PWM CONTROL CIRCUITS

#### DESCRIPTION

The UTC **UC3842A/3843A** provide the necessary functions to implement off-line or DC to DC fixed frequency current mode , controlled switching circuits with minimal external components.

#### FEATURES

- \*Low Start Up Current ( Typical 0.12mA )
- \*Automatic Feed Forward Compensation
- \*Pulse-by-Pulse Current Limiting
- \*Under-voltage Lockout with Hysteresis
- \*Double Pulse Suppression
- \*High Current Totem Pole Output to Drive MOSFET Directly
- \*Internally Trimmed Band Gap Reference
- \*500kHz Operation

#### ORDERING INFORMATION

Normal	Ordering Number		Package	Packing
	Lead Free Plating	Halogen Free		
UC3842A-D08-T	UC3842AL-D08-T	UC3842AP-D08-T	DIP-8	Tube
UC3842A-S08-R	UC3842AL-S08-R	UC3842AP-S08-R	SOP-8	Tape Reel
UC3842A-S08-T	UC3842AL-S08-T	UC3842AP-S08-T	SOP-8	Tube
UC3843A-D08-T	UC3843AL-D08-T	UC3843AP-D08-T	DIP-8	Tube
UC3843A-S08-R	UC3843AL-S08-R	UC3843AP-S08-R	SOP-8	Tape Reel
UC3843A-S08-T	UC3843AL-S08-T	UC3843AP-S08-T	SOP-8	Tube

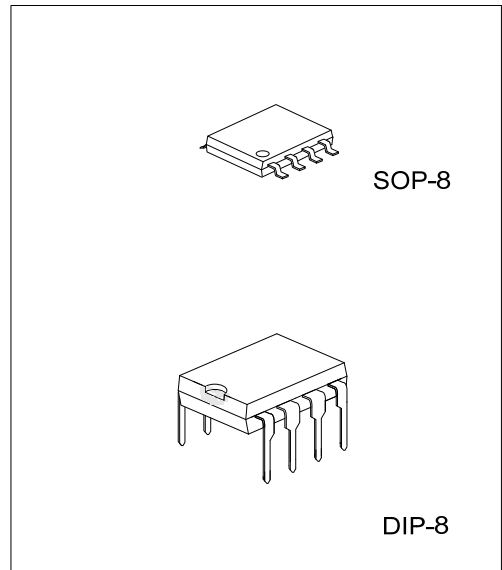

<p>UC3842AL-D08-T</p> <p>(1)Packing Type (2)Package Type (3)Lead Plating</p>	<p>(1) T: Tube, R: Tape Reel (2) D08: DIP-8, S08: SOP-8 (3) L: Lead Free Plating, Blank: Pb/Sn, P: Halogen Free</p>
--------------------------------------------------------------------------------------	-----------------------------------------------------------------------------------------------------------------------------

## ■ PIN CONFIGURATION

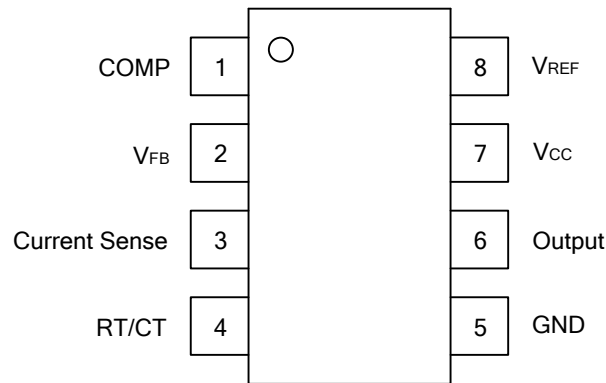

## ■ BLOCK DIAGRAM

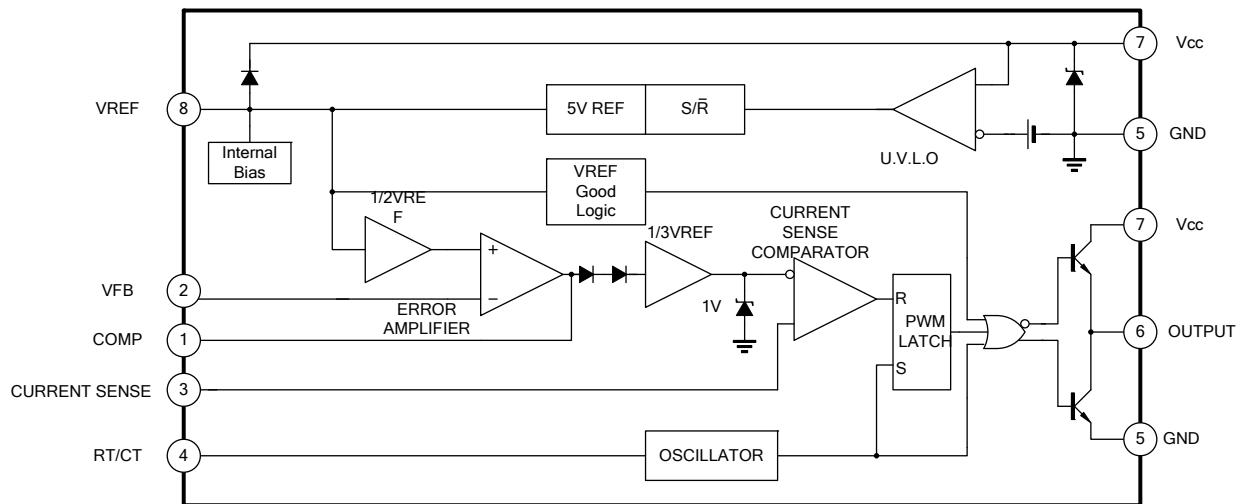

### ■ ABSOLUTE MAXIMUM RATINGS (Ta=25°C)

PARAMETER	SYMBOL	RATINGS	UNIT
Supply Voltage(Low Impedance Source)	V <sub>CC</sub>	30	V
Supply Voltage(I <sub>CC</sub> <30mA)	V <sub>CC</sub>	Self Limiting	V
Output Current ( Peak )	I <sub>O(PEAK)</sub>	±1	A
Output Energy (capacity Load)		5	μJ
Analog Inputs(pin 2,3)	V <sub>I(ANA)</sub>	-0.3 ~ +6.3	V
Error Amplifier Output Sink Current	I <sub>SINK(EA)</sub>	10	mA
Power Dissipation( Ta ≤ 25°C)	DIP-8	P <sub>D</sub>	1.0
	SOP-8		0.5
Derated at Ta>25°C	P <sub>D</sub>	8	mW/°C
Junction Temperature	T <sub>J</sub>	+150	°C
Storage Temperature	T <sub>STG</sub>	-65 ~ +150	°C

Note Absolute maximum ratings are those values beyond which the device which the device could be permanently damaged. Absolute maximum ratings are stress ratings only and functional device operation is not implied.

### ■ ELECTRICAL CHARACTERISTICS

(0°C ≤ Ta ≤ 70°C, V<sub>CC</sub>=15V, R<sub>T</sub>=10kΩ, C<sub>T</sub>=3.3nF, unless otherwise specified)

PARAMETER	SYMBOL	TEST CONDITIONS	MIN	TYP	MAX	UNIT
<b>Reference Section</b>						
Output Voltage	V <sub>REF</sub>	T <sub>J</sub> =25°C, I <sub>OUT</sub> =1mA	4.9	5	5.1	V
Line Regulation	ΔV <sub>REF</sub>	12 ≤ V <sub>IN</sub> ≤ 25V		6	20	mV
Load Regulation	ΔV <sub>REF</sub>	1 ≤ I <sub>OUT</sub> ≤ 20mA		6	25	mV
Temperature Stability		(Note 1)		0.2	0.4	mV/°C
Total Output Variation		Line, Load, Temp(Note 1)	4.82		5.18	V
Output Noise Voltage	V <sub>osc</sub>	10Hz ≤ f ≤ 10kHz, T <sub>J</sub> =25°C (Note 1)		50		μV
Long Term Stability		Ta=25°C, 1000Hrs(Note 1)		5	25	mV
Output Short Circuit	I <sub>sc</sub>		-30	-100	-180	mA
<b>Oscillator Section</b>						
Initial Accuracy	f	T <sub>J</sub> =25°C	47	52	57	kHz
Voltage Stability	Δf/ΔV <sub>CC</sub>	12 ≤ V <sub>CC</sub> ≤ 25V		0.2	1	%
Temperature Stability		T <sub>min</sub> ≤ Ta ≤ T <sub>max</sub> (Note 1)		5		%
Amplitude	V <sub>osc</sub>	V <sub>pin 4</sub> peak to peak		1.7		V
<b>Error Amplifier Section</b>						
Input Voltage	V <sub>I(EA)</sub>	V <sub>pin 1</sub> =2.5V	2.42	2.50	2.58	V
Input Bias Current	I <sub>I(BIAS)</sub>			-0.3	-2	μA
AVOL		2 ≤ V <sub>OUT</sub> ≤ 4V	60	90		dB
Unity Gain Bandwidth		T <sub>J</sub> =25°C (Note 1)	0.7	1		MHz
PSRR		12 ≤ V <sub>CC</sub> ≤ 25V	60	70		dB
Output Sink Current	I <sub>O(SINK)</sub>	V <sub>pin 2</sub> =2.7V, V <sub>pin 1</sub> =1.1V	2	6		mA
Output Source Current	I <sub>O(SOURCE)</sub>	V <sub>pin 2</sub> =2.3V, V <sub>pin 1</sub> =5V	-0.5	-0.8		mA
V <sub>OUT</sub> High	V <sub>OH</sub>	V <sub>pin 2</sub> =2.3V, R <sub>L</sub> =15kΩ to GND	5	6		V
V <sub>OUT</sub> Low	V <sub>OL</sub>	V <sub>pin 2</sub> =2.7V, V <sub>pin 1</sub> =1.1V		0.7	1.1	V

### ■ ELECTRICAL CHARACTERISTICS(Cont.)

PARAMETER	SYMBOL	TEST CONDITIONS	MIN	TYP	MAX	UNIT	
<b>Current Sense section</b>							
Gain	$G_V$	(Note 2,3)	2.85	3	3.15	V/V	
Maximum Input signal	$V_{I(MAX)}$	Vpin 1=5V( Note 2)	0.9	1	1.1	V	
PSRR		$12 \leq V_{CC} \leq 25V$		70		dB	
Input Bias Current	$I_{BIAS}$			-2	-10	$\mu A$	
Delay to Output		Vpin 3=0 to 2V		150	300	ns	
<b>Output Section</b>							
Output Level	Low	$V_{OL}$	$I_{O(SINK)}=20mA$		0.1	0.4	V
			$I_{O(SINK)}=200mA$		1.5	2.2	V
	High	$V_{OH}$	$I_{O(SOURCE)}=20mA$	13	13.5		V
			$I_{O(SOURCE)}=200mA$	12	13.5		V
Rise Time	$t_R$	$T_J=25^\circ C, C_L=1nF$ (Note 1)		50	150	ns	
Fall Time	$t_F$	$T_J=25^\circ C, C_L=1nF$ (Note 1)		50	150	ns	
<b>Under-Voltage Lockout Output Section</b>							
Start Threshold	3842A	$V_{TH(ST)}$		14.5	16	17.5	V
	3843A			7.8	8.4	9	V
Min. Operating Voltage	3842A	$V_{OPR(MIN)}$	After Turn On	8.5	10	11.5	V
	3843A			7	7.6	8.2	V
<b>PWM Section</b>							
Duty Cycle	MAX	$D_{(MAX)}$		95	97	100	%
	Min	$D_{(MIN)}$				0	%
<b>Total Standby Current</b>							
Start-up Current		$I_{ST}$		0.12	0.3	mA	
Operating Supply Current		$I_{CC(OPR)}$	Vpin 2=Vpin 3=0V		11	17	mA
$V_{CC}$ Zener Voltage		$V_z$	$I_{CC}=25mA$		34		V

Note:1. These parameters, although guaranteed, are not 100% tested in production.

2. Parameters measured at trip point of latch with Vpin 2=0.

3. Gain defined as:

$$A = \frac{\Delta V_{pin 1}}{\Delta V_{pin 3}} ; 0 \leq V_{pin 3} \leq 0.8V$$

4. Adjust  $V_{CC}$  above the start threshold before setting at 15V.

## ■ OPEN-LOOP LABORATORY TEST FIXTURE

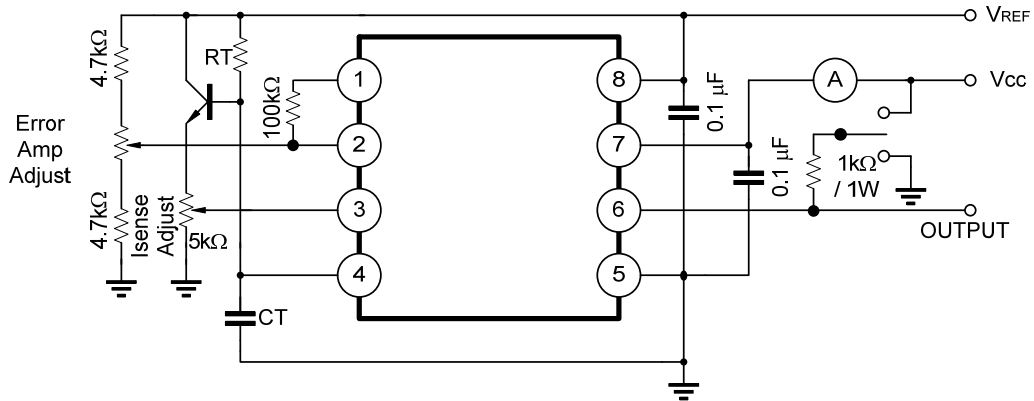

High peak current associated with capacity loads necessitate careful grounding techniques. Timing and bypass capacitors should be connected close to pin 5 in single point GND. The transistor and 5kΩ potentiometer are used to sample the oscillator waveform and apply an adjustable Ramp to Pin 3.

## ■ UNDER-VOLTAGE LOCKOUT

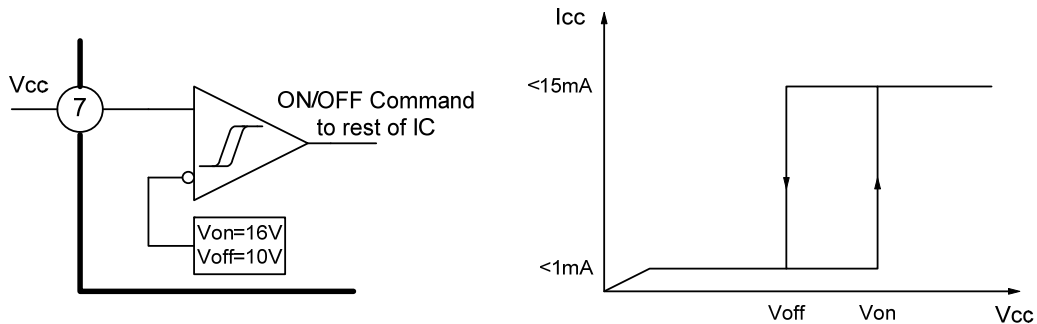

During Under-Voltage Lockout, the output driver is biased to a high impedance state. Pin 6 should be shunt to GND with a bleeder resistor to prevent activating the power switch with output leakage currents.

## ■ ERROR AMPLIFIER CONFIGURATION

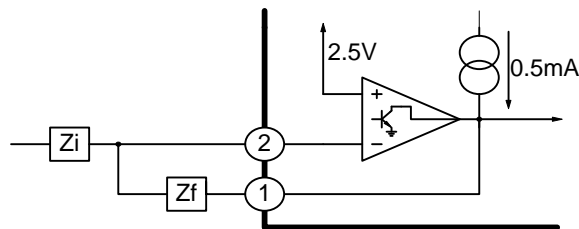

Error amplifier can source or sink up to 0.5mA

## ■ CURRENT SENSE CIRCUIT

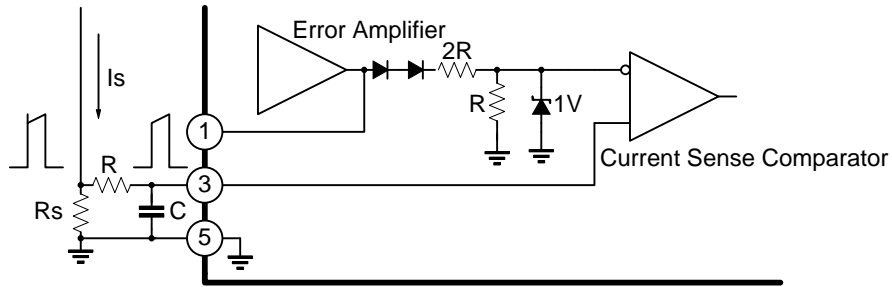

Peak current ( $I_s$ ) determined by the formula:  $I_{smax} = 10V/R_s$ .  
 A small RC filter be required to suppress switch transients.

## ■ SLOPE COMPENSATION

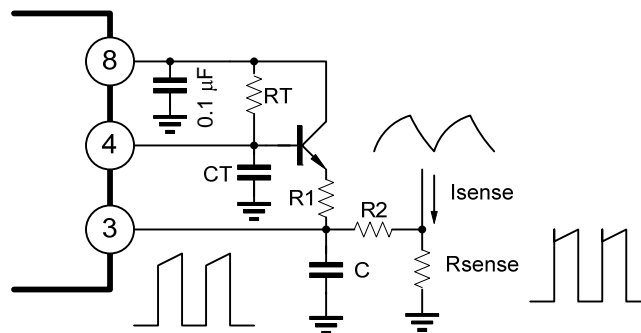

A fraction of the oscillator ramp can be resistively summed with the current sense signal to provide slope compensation for converts requiring duty cycles over 50%. Note that capacitor C, forms a filter with R2 to suppress the leading edge switch spikes.

## ■ OSCILLATOR SECTION

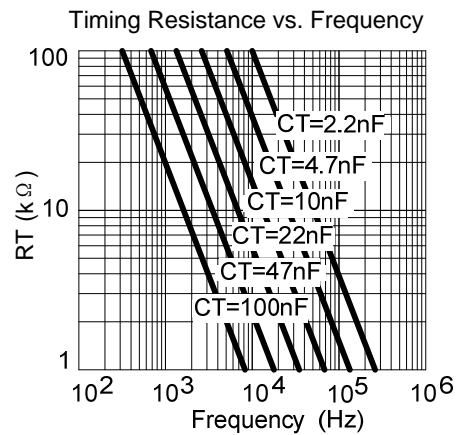
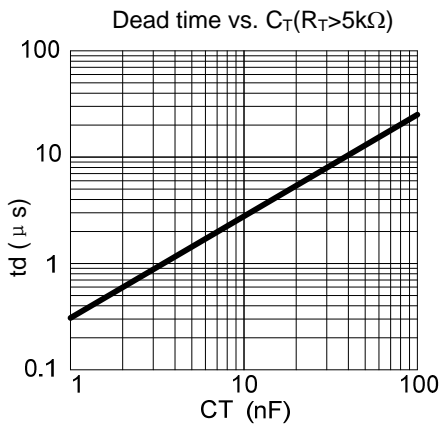
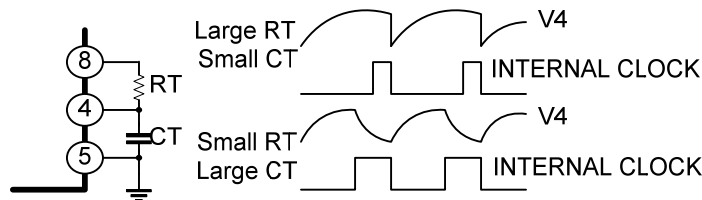

### ■ SHUTDOWN TECHNIQUES

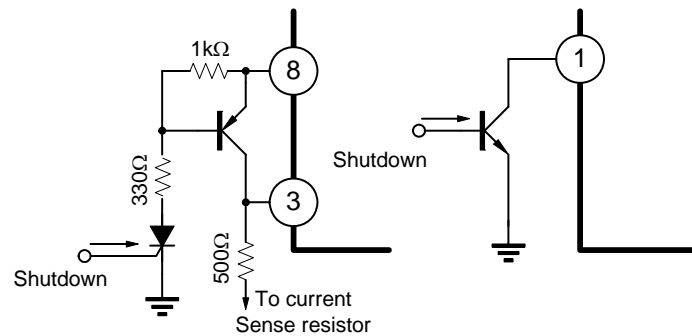

Shutdown UTC **UC3842A** can be accomplished by two methods; either raise pin 3 above 1V or pull Pin 1 below a voltage two diode drops above ground. Either method caused the output of PWM comparator to be high (refer to block diagram). The PWM latch is reset dominant so that the output will remain low until the next clock cycle after the shutdown condition at pins 1 and/or 3 is removed. In one example, an externally latched shut-down may be accomplished by adding an SCR which be reset by cycling  $V_{CC}$  below the lower UVLO threshold. At this point the reference turns off allowing the SCR to reset.

## TYPICAL CHARACTERISTICS

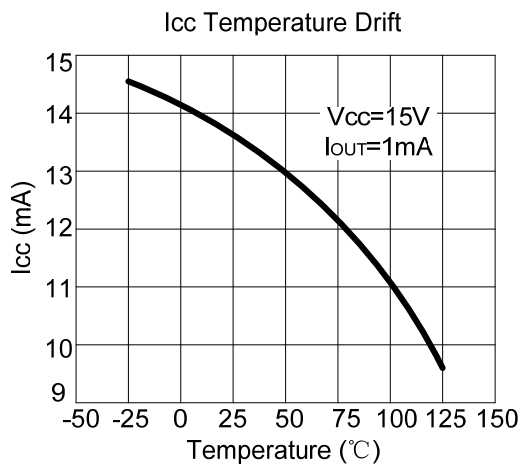
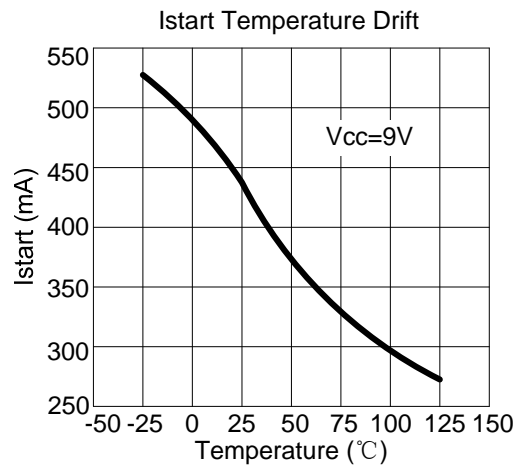
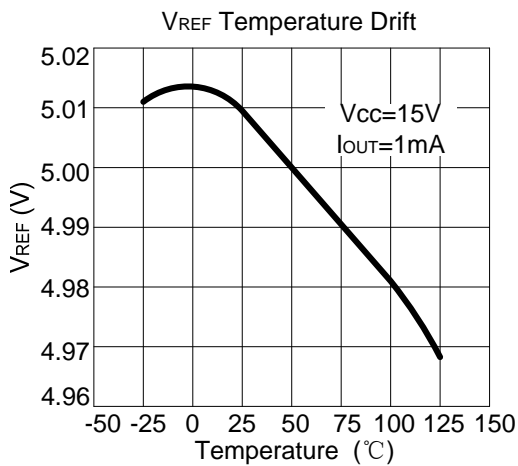
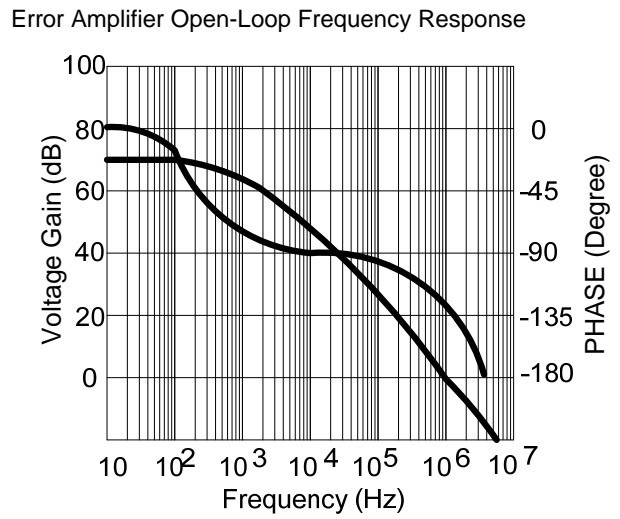
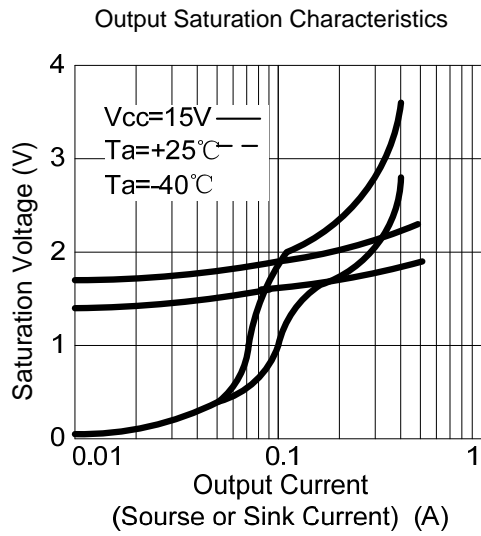

UTC assumes no responsibility for equipment failures that result from using products at values that exceed, even momentarily, rated values (such as maximum ratings, operating condition ranges, or other parameters) listed in products specifications of any and all UTC products described or contained herein. UTC products are not designed for use in life support appliances, devices or systems where malfunction of these products can be reasonably expected to result in personal injury. Reproduction in whole or in part is prohibited without the prior written consent of the copyright owner. The information presented in this document does not form part of any quotation or contract, is believed to be accurate and reliable and may be changed without notice.